



QUEEN CITY YACHT CLUB
ALGONQUIN ISLAND, TORONTO

September, 1968

CHEATER'S RACE

The Annual Queen City Yacht Club Cheater's Race will be held Saturday, September 28th. Continuing the well established tradition, all skippers will gather at the bar, glass of spirits in hand and will down the glass at the command "bottom's up". This quaint ceremony will take place at 1:00 pm and all competing skippers are requested to have their glasses amply charged by then. Glasses must be emptied at the bar before leaving for the boats. All keel boats shall be unrigged and lying at anchor anywhere within the lagoon south of a line between the flag pole and the north end of the ferry docks. Centreboard boats may be on the dock, spars stepped but no sails rigged. After downing the booze skippers are to dash to boats and, proceeding under any means of power other than mechanical (no motors etc.), circumnavigate the Toronto Islands in the direction of the skippers choice. No marks are to be observed during this circumnavigation, commonsense is to dictate safety considerations. The finish line will be between the flagpole and the north end of the ferry docks. A crock of booze will be awarded the winner. Protests may be heard but it is unlikely. John Perdue has arranged for one of his usual splendid bashes to wind up the festivities of the event. Geoff Berry's Cheatin' 6 will be on hand to blast the night away. Come on you cheaters -- now's your chance.

ASSESSMENT IS PAST DUE!

Nearly 80 members have yet to remit their \$25.00 assessment, and this money is now urgently needed, in order to reduce our bank indebtedness as much as possible. The interest on \$5,000 is equivalent to the entire yearly ~~revenue from~~ two senior memberships, and it is in the best interests of the club and its members that bank loans be cleared up as quickly as possible. Those not paying their fair share will be considered in arrears, so please remit without delay.

TENDER SCHEDULE CHANGES

Effective Monday, September 30th, the weekday tender schedule is revised as follows: 4:45pm, 5:15, 5:45, 6:15, 7:15, 8:15, 9:15, 10:15. Weekend schedule remains unchanged.

CRADLE SPECS

In this issue we're printing specifications and design for what should become the QCYC Standard Boat Cradle, drawn up by Al Rae in consultation with Marine Yard Chairman Bob Norton. Earlier in the season Bob announced that some cradles in the yard were unsafe, and their owners will be notified shortly of this condition. No boats will be hauled out in unsafe cradles this year. So look over the drawing, and look over YOUR cradle.

**DRAWING SHOWS
STANDARD CONSTRUCTION
FOR BOATS UP TO 2 TON**

UPRIGHTS

UP TO 2 TON	-	4 x 4	Cedar/FIR
" 4 "	"	4 x 6	"
" 6 "	"	4 x 8	"
" 10 "	"	6 x 6	"

CROSSBARS

2 TON	2 x 4
4 "	2 x 6
6 "	2 x 6
10 "	2 x 8

CROSS BRACES

2 TON	1 x 4
4 "	1 x 6
6 "	1 x 6
10 "	1 x 8

KEEL TIMBER

2 TON	4 x 10
4 "	4 x 10
6 "	6 x 10
10 "	8 x 12

BASE TIMBER

2 TON	6 x 8
4 "	6 x 8
6 "	8 x 10
10 "	10 x 12

ABOVE FIR OR SPRUCE

6 1/2" OR 78" NARROW GAUGE WIDE GAUGE

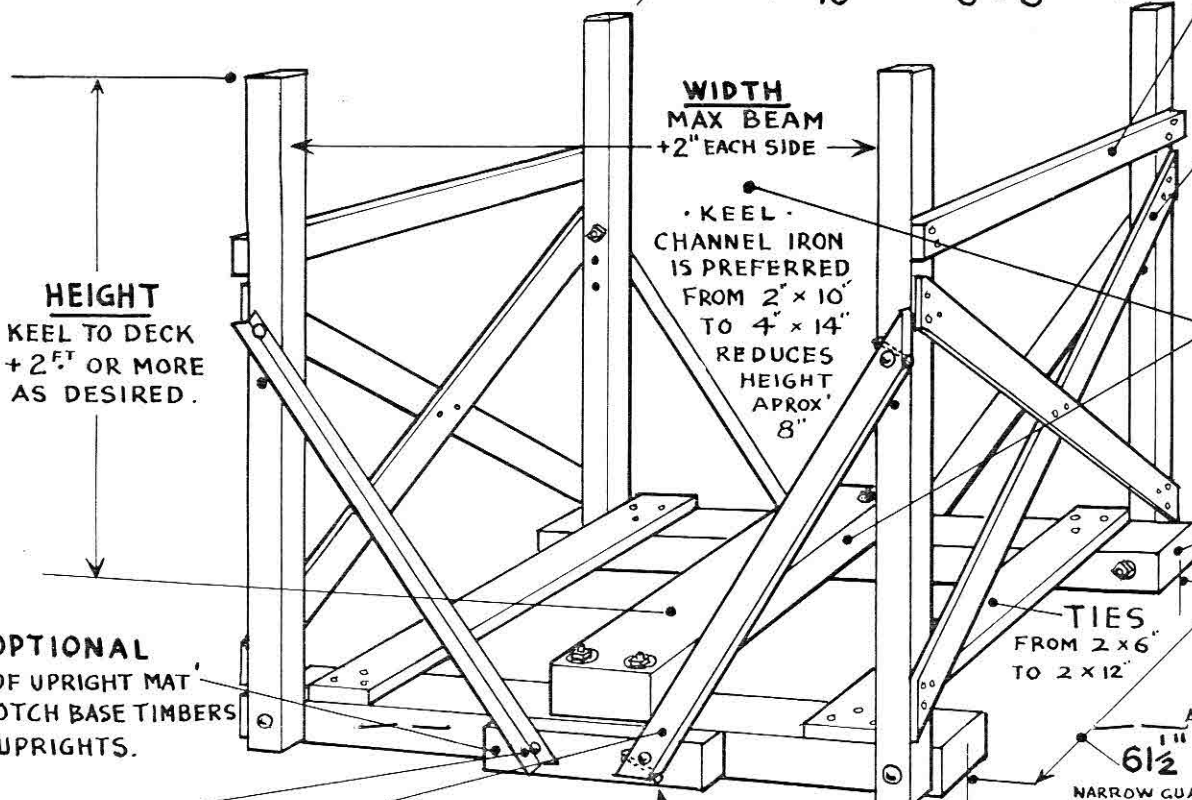

WIDTH
MAX BEAM
+ 2" EACH SIDE

• KEEL •
CHANNEL IRON
IS PREFERRED
FROM 2" x 10"
TO 4" x 14"
REDUCES
HEIGHT
APPROX
8"

HEIGHT
KEEL TO DECK
+ 2 FT OR MORE
AS DESIRED.

OPTIONAL
PAD OF UPRIGHT MAT
OR NOTCH BASE TIMBERS
FOR UPRIGHTS.

TIES
FROM 2 x 6"
TO 2 x 12"

ANGLE IRON WOOD STRUTS

1 1/2"	"	2	TON - 2 x 4	FIR
2"	"	4	" - 2 x 6	"
3"	"	6	" - 2 x 8	"
4"	"	10	" - 2 x 10	"

IF WOOD IS USED BOLT ENDS TO PREVENT SPLITTING
STEEL ANGLE IS RECOMMENDED - 2 EXTRA HOLES ALLOW
OPENING UP CRADLE FOR PAINTING AFTER SHORING

2 x 8 ONLY

PLEASE DON'T USE 10" OR 12"

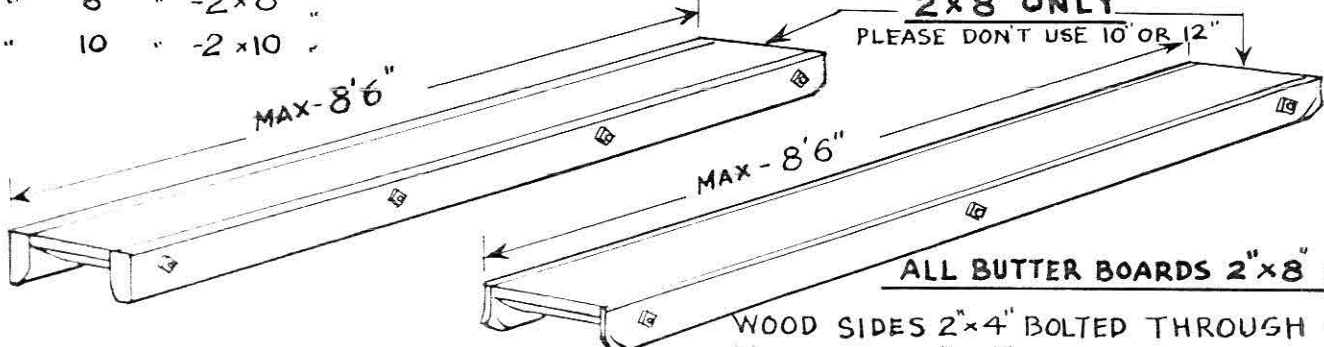

ALL BUTTER BOARDS 2" x 8" FIR

WOOD SIDES 2" x 4" BOLTED THROUGH 4 BOLTS
IRON SIDES 1/4" x 3 1/2" BOLTED THROUGH 3 BOLTS

TOPS & GUIDES MUST BE CHAMPHORD
SIDES MUST BE BOLTED NO LAG SCREWS.

SAFETY IS THE MAIN REASON, NOT ONLY FOR THE BOAT BUT PEOPLE CAN GET HURT IF A BOAT FALLS, ALSO PROPER CRADLES SPEED UP OUR OPERATION
PS. CREOSOTING YOUR WOOD WILL DOUBLE THE LIFE OF YOUR CRADLE!
FOR BOATS WITH UNCONVENTIONAL UNDERBODIES SEE MARINE CHAIRMAN!

For next month's issue, we invite you to advertise, free of charge, any boats, equipment, accessories or hardware for which you may have no further use, but which someone else might need. Look through that carton of No. 1 Select Junk: someone will pay cash money for those odd cleats, or that unwanted block. Looking for boat equipment? Advertise in the next issue of The Clipper. All notices to Bas Headford, 364-7544 (days), 261-3682 (evenings).

LOCKERS FOR THE LADIES

A LOCKER BLOCK (formerly the Junior Club House) has been furnished for the use of the Queen City ladies. All those wishing to use this facility should contact Mr. Fred Poole without delay. If insufficient interest is indicated, the building will be put to other use, so get your request in now, girls.

CORN ROAST AT SUNDOWN

September 28, 1968

Gorgeous gobs of cobs from
Ken Sinclair's back Forty

and in

THE GREAT HALL

The Queen City Beer, Chowder and
Propagation Society Marching Band
will feature Geoff Berry and his Six
Cheaters on a scenic trip through Dixie.

TURN UP!

TURN ON!

THE CLIPPER

Newsletter of the Queen City Yacht Club, Algonquin Island, Toronto. News of happenings of interest to members are welcome, also your comments and criticism, photographs and drawings. Send all communications to Bas. M. Headford, 10 Granard Blvd., Scarborough, or to Publicity Committee member Herb Pitcher. The Clipper will appear monthly until the end of the sailing season.
